

22U Adjustable Depth Open Frame Swing Out Wall Mount Rack - 301 Series, Flat Packed

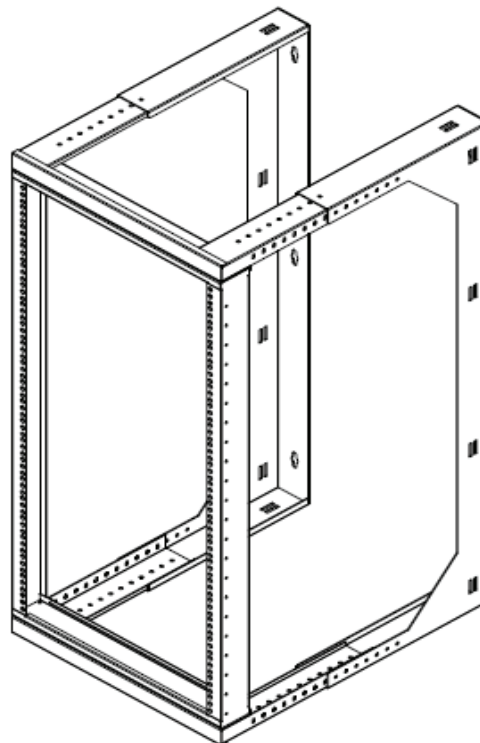
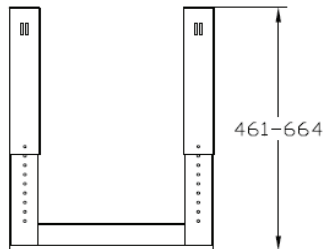
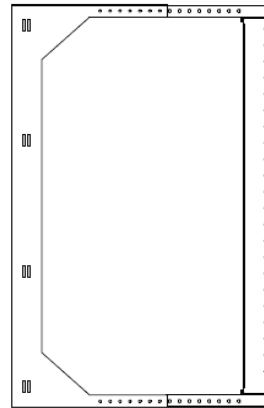
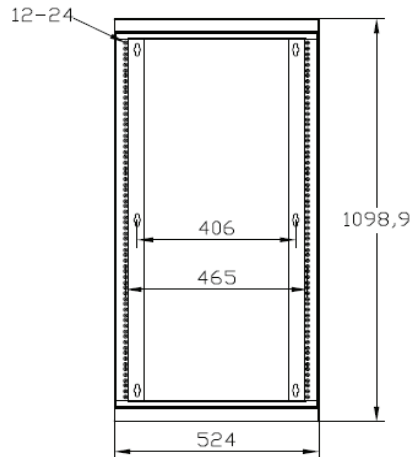

Maximize Floor Space: Frees up valuable floor space by securing equipment off the ground and onto the wall, ideal for optimizing room in crowded or compact environments.

Easy Access: Open frame design provides easy access to equipment and cables for maintenance, upgrades, or troubleshooting.

Enhanced Airflow: The open structure ensures continuous airflow, helping to keep equipment cool and reduce the risk of overheating.

Versatile Installation: Can be mounted in various locations, including closets, under desks, or in any area where space is at a premium.

Swing-Out Design: Equipped with a practical swing-out mechanism that allows the rack to pivot for easy access to the rear of mounted equipment, simplifying maintenance and setup.

Adjustable Depth: Offers an adjustable depth from 18 to 28 inches, accommodating a variety of equipment sizes and installations, providing flexibility for different networking needs.

Compliance	EIA-310D
Delivery Style	Knockdown
Dual Tapped Rails	Yes (#12-24)
Electrostatic Powdercoat MicroFinish	Black
Hinged Swing Out Design	Yes
Load Capacity	150 lbs
Mounting Format	19"
Numbered RU positions	Yes
Rack Height (Assembled)	44 Inch
Rack Size Depth (Internal)	18-28"
Rack Size Width (Internal)	21" (19")
RMU	22U
Screws & Washers (#12-24)	16 each